



Client:

Project:

Type:

Order Code:

Quantity:

Flex Tube SC is a flexible, single color, indoor/outdoor LED strip, available in multiple color temperatures and mounting orientations. It comes in seven-meter spool or custom-built lengths to suit project requirements and features a highly durable second-generation silicone body, which is outdoor rated and high impact resistant.

SPECIFICATIONS

Colors	2200K, 2700K, 3000K, 3500K, 4000K, 5700K, Red, Green, Blue, Amber
Beam Angle	120°
Photometrics	Up to 215 lumens per foot, 80 CRI, 3 step SDCM, see page 4 for details
Strip Length	Built to order lengths from 4.37" (111mm) to 22.96' (7m), section length 2.18" (55.56mm)
Dimming	DMX/RDM (0-100%), DALI (0-100%), 0-10V (1-100%), TRIAC (1-100%), ELV (1-100%)
Bend Directions & Radius	Vertical bending or horizontal bending options, minimum bend radius of 5.9" (150mm)
Power Consumption	3.65W per foot, 12W per meter except Red and Amber - 2.43W per foot, 8W per meter
Operating Voltage	24VDC
Lumen Maintenance	L70 @ 50,000 hours (25° C)
Mounting	Aluminum mounting channel required, 0.78" (20mm), 11.8' (1m), or 6.56' (2m) lengths
Finish	White
Material	UV resistant silicone
Ambient Operating Temperature	-40° F to 131° F (-40° C to 55° C)
IP Rating	IP68, wet location, submersible* up to 6.56' (2m)
IK Rating	IK08, protection against 5 joule impact
Fixture Connectors	16.4' (5m) injection molded feed cable and end cap included
Warranty	5 Years, limited
Weight	5.73 lbs (2.59 kg) - 7m Spool
Dimensions	L: As specified W: 0.62" H: 0.66" / L: As specified W: 16mm H: 17mm

Certifications



*UL approval limits submersible installation to non-human occupied and freshwater locations only. All cables must be landed in environmentally suitable junction boxes.

ORDER CODES

* indicates special order

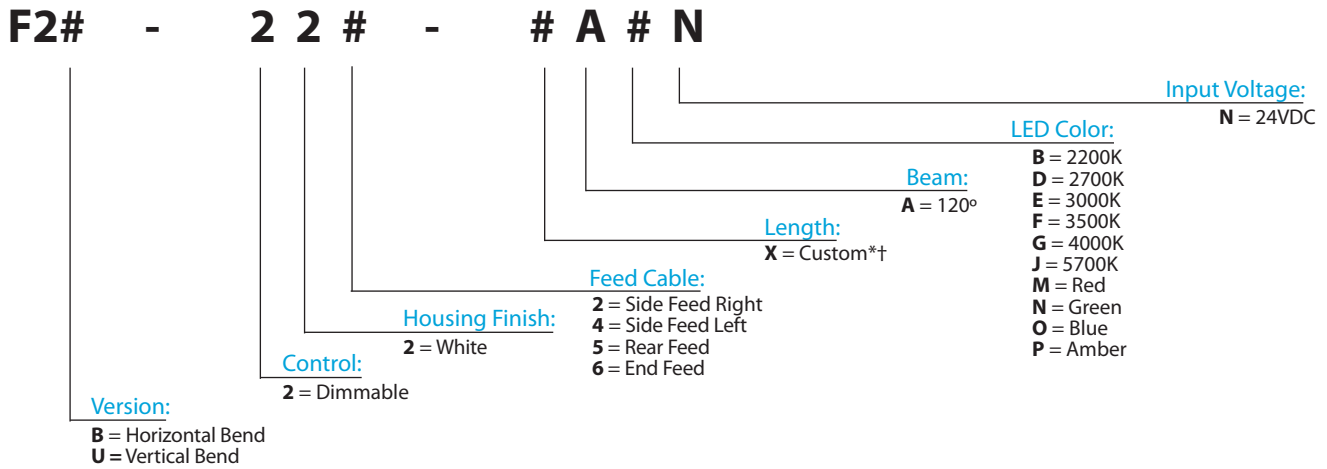

†: When ordering custom lengths, please specify number of 2.18" (55.56mm) sections required after X (4.37" / 111mm min - 22.96', 7m max).
 Example order code: **F2B-225-X40AQN = 55.56mm x 40 / 2.22m spool**

FEED CABLE LOCATIONS



HORIZONTAL BEND

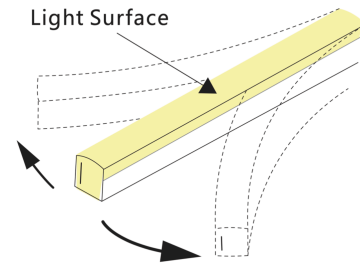

VERTICAL BEND

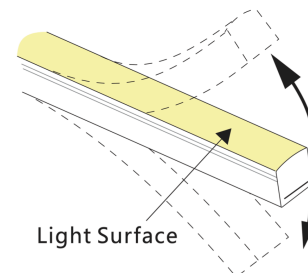

TWO WIRE CABLE LIMIT

Gauge	Conductors	Max Amperage	Max feet to tube
18 AWG	2	4	40
14 AWG	2	4	100
12 AWG	2	4	170

RELATED COMPONENTS

Mounting Accessories



F2CH20
20mm (0.78") Gen 2 mounting channel
Aluminum profile, includes 2 screws

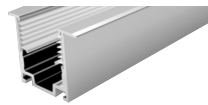

F2RCH20
20mm (0.78") Gen 2 recessed mounting channel
Aluminum profile, includes 2 screws



F2FCH500
0.5M (1.64') Gen 2 flexible mounting channel
Only for HB versions, includes 2 screws

F2CH1000
1M (3.28') Gen 2 mounting channel
Aluminum profile, includes 5 screws

F2RCH1000
1M (3.28') Gen 2 recessed mounting channel
Aluminum profile, includes 5 screws

F2FCH1000
1M (3.28') Gen 2 flexible mounting channel
Only for HB versions, includes 5 screws

F2CH2000
2M (6.56') Gen 2 mounting channel
Aluminum profile, includes 10 screws

F2RCH2000
2M (6.56') Gen 2 recessed mounting channel
Aluminum profile, includes 10 screws

DMX Multi Protocol Drivers AL Driver 200/400/800

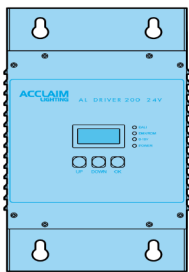

ALD-200-24 C2
AL Driver 200 24V, 2 spools max
200W 24V Class 2 power supply
DMX, 0-10V (sink & source) & DALI driver
4 output ports, 100-277VAC input

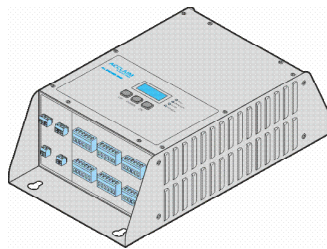

ALD-400-24 C2
AL Driver 400 24V, 4 spools max
400W 24V Class 2 power supply
DMX, 0-10V (sink & source) & DALI driver
6 output ports, 100-277VAC input

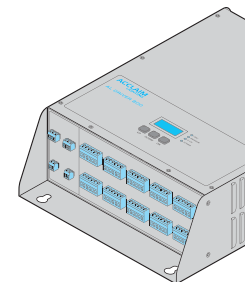

ALD-800-24 C2
AL Driver 800 24V, 8 spools max
800W 24V Class 2 power supply
DMX, 0-10V (sink & source) & DALI driver
10 output ports, 100-277VAC input

RELATED COMPONENTS

0-10V + TRIAC (Forward Phase) Drivers



MLE96-24DC-UD
 24VDC PWM Driver, 1 spool max
 96W 24V Class 2 LED Driver, 5-100%
 0-10V (sink) & TRIAC (forward phase) dimming
 100-277VAC input



MLE192-24DC-UD
 24VDC PWM Driver, 2 spools max
 192W 24V Class 2 LED Driver, 5-100%
 0-10V (sink) & TRIAC (forward phase) dimming
 100-277VAC input



MLE288-24DC-UD
 24VDC PWM Driver, 3 spools max
 288W 24V Class 2 LED Driver, 5-100%
 0-10V (sink) & TRIAC (forward phase) dimming
 100-277VAC input

PHOTOMETRICS

Bend /Color	Lumens (per foot)	Max Candela	CRI	TM30
HB 2200K	149	47.5	80.7	83.1
HB 2700K	157	52.5	83.1	81.8
HB 3000K	154	49.1	86.2	86.2
HB 3500K	155	49.1	84	84.9
HB 4000K	151	50.5	84.1	83.7
HB 5700K	151	47.9	84.3	83.2
HB Red	60	19.3	-	-
HB Green	182	58.4	-	-
HB Blue	38	12.6	-	-

Bend /Color	Lumens (per foot)	Max Candela	CRI	TM30
VB 2700K	182	61.3	83.4	81.7
VB 3000K	187	62.7	85.3	83.7
VB 3500K	189	63.5	82.0	82.8
VB 4000K	183	61.1	84.5	84.9
VB 5700K	188	63	83.3	82.4
VB Green	215	69.4	-	-
VB Blue	43	15	-	-

DIMENSIONS

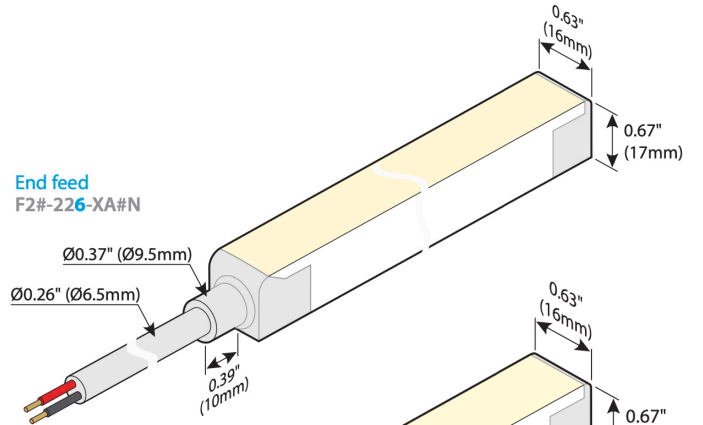
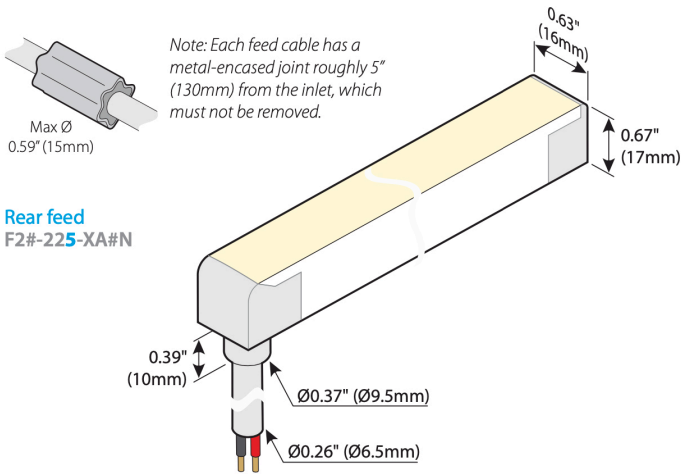

Left side feed
F2#-224-XA#N

Right side feed
F2#-222-XA#N

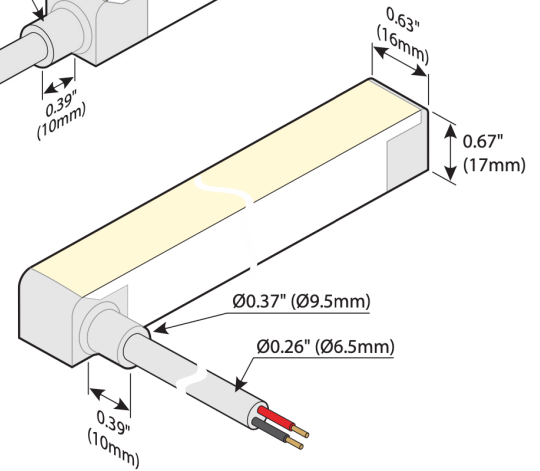

Flex Tube Gen 2

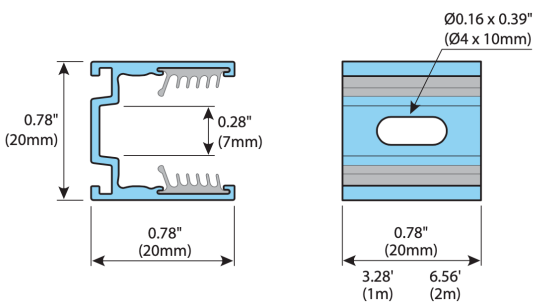

Flex Tube Gen 2 Recessed

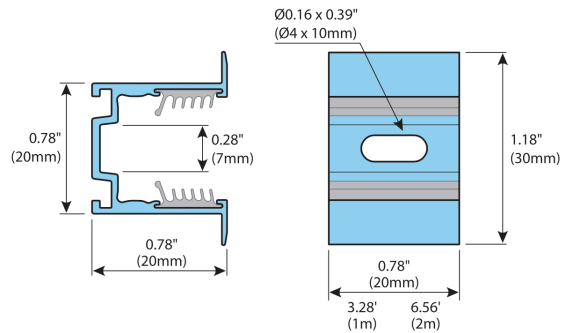

Flex Tube Gen 2 Flexible

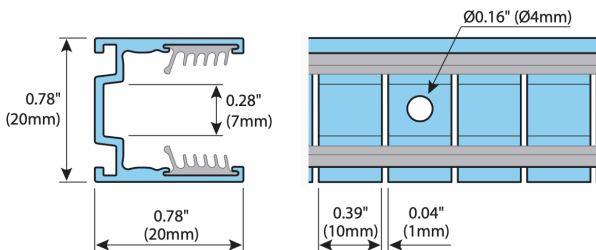

Note: The Ø0.16" (4mm) mounting holes are spaced at 4.57" (116mm) - on every tenth segment.