

Overview

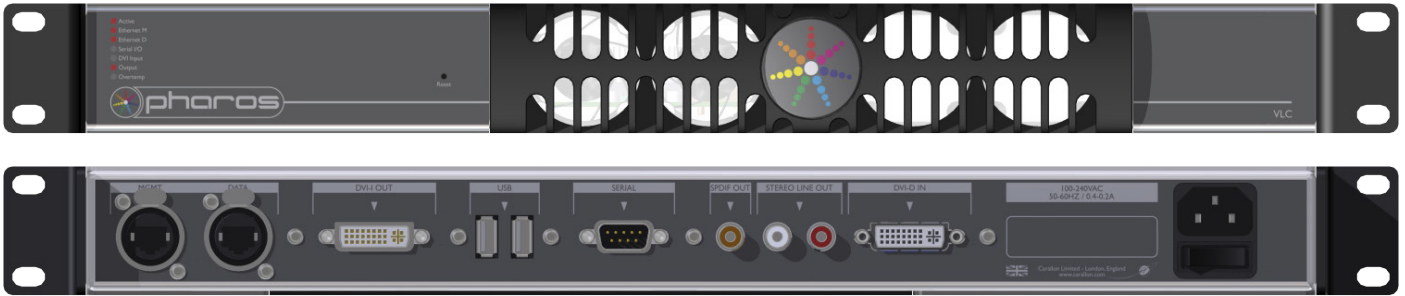

The Pharos VLC (Video Lighting Controller) is an extremely capable but cost effective solution for large LED pixel arrays such as building façades, bridges, and presentation walls. It makes it simple to play video content across your array, either from locally stored HD media files or a DVI-D video input. It also offers a range of creative generative effects, the versatility of powerful show control, and integration features.

Features



Render Engine

Make your light fixtures a canvas onto which you can paint with creative effects or video playback. The powerful Designer 2 software allows you to build your fixture layout fast with pixel-precise adjustment. Then use individually controllable and independently running timelines to build dynamic, striking, pre-programmed lighting displays across your canvas.



Pharos Trigger

Timing is everything. Whatever the stimulus, Pharos Trigger can handle it. You can control your lighting with responsive, reactive programming. Pharos Trigger is a rules engine that uses conditional logic and a broad range of interfaces and protocols. Send and receive any command, to and from any system. Conditional logic is supported, along with a powerful built-in scripting language for unlimited flexibility.



High Capacity

Big just got a whole lot easier. The VLC can output all commonly used eDMX protocols (sACN, Art-Net, KiNET, EDN 20) over Gigabit Ethernet and there are no restrictions on using these protocols simultaneously. There are six VLC variants with pricing based on channel capacity, ranging from 25,600 channels up to a massive 768,000 channels.

Scalable

The right fit for every installation. Multiple Pharos Controllers can be seamlessly linked together to work as one via a standard Ethernet network giving impressive scalability. For additional integration options simply add Remote Devices to further extend the network. Whether one Controller or many, it's all easily programmed using our Designer software.

High Definition

Live video can be captured on the DVI-D input at resolutions up to 1080p60. Internal video playback at up to 1080p30 supports all major formats such as H.264/MPEG-4 AVC, MJPEG and QuickTime. The built-in 128GB SSD provides plenty of capacity for media storage.

Remote Management

The control you need in your browser - from anywhere. Pharos Controllers can be connected to Pharos Cloud, a secure remote management service from SixEye. This allows direct control of your Controllers from anywhere in the world, letting you check all of your Controllers' statuses, inputs and outputs, firing triggers, scheduling events, uploading new projects and much more. All Pharos controllers also have their own Web Interface that can be accessed on a local area network that provides real-time statuses, access to the full log and the ability to fire triggers on the controller.

Custom Interfaces

Create a custom web interface for your installation that gives your users the control they need and the look they expect. Our built-in web server supports an extensive JavaScript API and access control with multiple user levels.

Pharos Designer

Programmed and configured using the free Pharos Designer software – available for Windows or Mac OS X – with upload over Ethernet.

Reliable

Hardware and firmware are self-sufficient, so no PC needs to be left on site. Rugged, compact unit designed for 24/7 operation and reliability.

5 Year Warranty

Designed and manufactured in the UK, with quality and reliability our top priority.

Certifications

CE compliant, ETL/cETL listed, and California Title 20/24 compliant.



Supported Fixtures

LEDs	LEDs in any colour configuration (RGB, RGBW, 8-bit, 16-bit, tuneable white)
Fixture Library	Pharos offers a cloud library with over 13,000 fixture profiles, for easy download of your luminaires

Output

sACN	USITT E1.31 (with per fixture priority)
Art-Net	ArtNet, ArtNet II and ArtNet III (configurable broadcast override)
KiNET	KiNET V1 (DMX out) and V2 (Port out); PDS/Data Enabler discovery
Pathport	Pathway Connectivity protocol
DMX512	Via the EDN or any other eDMX node
Scalable Simultaneous	Synchronises with up to 40 Pharos Controllers over network. Multiple protocols can be in operation simultaneously. Limited by patched channels, not universes used
EDN	Can natively integrate with and output DMX through the ports of the EDN (Ethernet Data Node, supplied separately)
Audio Out	Audio Output with two audio layers; a background layer for ongoing audio, and an alert layer for high-priority overriding

Triggering & Integration

Startup Clock	Commences playback automatically on receiving power. Battery-backed real-time clock for calendar and time-based triggers
Astronomical Ethernet	Sunrise/Sunset/Twilight and Lunar phases
Serial Data	UDP, TCP, Multicast; send/receive any Ethernet message. RS232; configurable port; send/receive free syntax in ASCII, HEX or decimal
eDMX Inputs	sACN or Art-Net. Contact closure, active low, active high or 0-24V analog level via RIOs
Outputs	Isolated relay outputs (48V 250mA) via RIOs
MIDI	MIDI Notes, SysEx or Timecode via RIO A
Timecode	Linear Timecode via RIO A (SMPTE, Film, EBU, NTSC)
Audio Level	Stereo 30-band spectrum analysis via RIO A
RS485	RS485 Serial via RIO; configurable port; send/receive free syntax in ASCII, HEX or decimal
DALI	Trigger on any message, via RIO D
Web Interface	Built-in or custom designed
Wall Stations	Integrate with BPS, TPS or TPC
Conditions	Full conditional logic support
Scripting	Lua scripting for total flexibility
Scalable	Supports Pharos Remote Devices
IO Modules	Supports our extensive IO Module library for easy integration

Interfaces

Ethernet	Neutrik etherCon (RJ45 compatible) for 10/100/1000Base-TX Ethernet; Static IP or DHCP
eDMX	Dedicated Ethernet port for eDMX; Neutrik etherCon (RJ45 compatible) for 10/100/1000Base-TX Ethernet; Static IP or DHCP
DVI-D Input	Video input to capture resolutions up to 1080p60
DVI-I Output	DVI-I output (for future development)
Serial	RS232 via DB9 connector
USB	Two USB 2.0 Type A ports (for future development)
Audio Outputs	Stereo analog & digital audio ports

Specifications

Certifications	CE compliant, ETL/cETL listed
Power	100-240VAC / 50-60HZ / 0.25-0.1A 25W typical (30W maximum) IEC connector with switch * * Power cable not supplied
Data Storage	Internal 128GB SSD (supplied)
Configuration	Pharos Designer 2.2 or later
Temperature	0°C to 50°C (32°F to 122°F)
Humidity	10-50% relative, non-condensing
Ingress	IP40
Physical	19" rack unit, 1U, 13.5" deep 3.1 kg (6.8 lbs)
Shipping	57 x 45 x 18 cm (22" x 18" x 7") 5.0 kg (11 lbs)
Recovery	Hardware watchdog and recessed reset button
Warranty	5 years

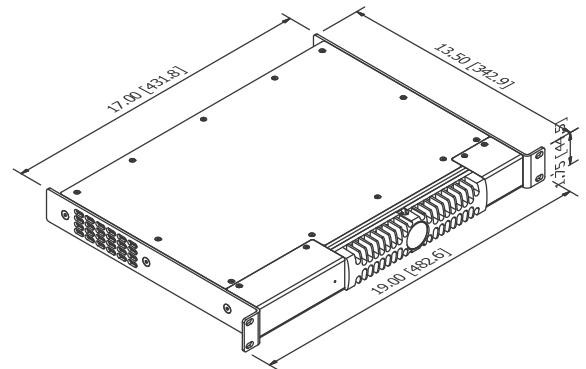

Order Code & Variants

VLC 50	Video Lighting Controller 50 (25,600 channels eDMX)
VLC 100	Video Lighting Controller 100 (51,200 channels eDMX)
VLC 250	Video Lighting Controller 250 (128,000 channels eDMX)
VLC 500	Video Lighting Controller 500 (256,000 channels eDMX)
VLC 1000	Video Lighting Controller 1000 (512,000 channels eDMX)
VLC 1500	Video Lighting Controller 1500 (768,000 channels eDMX)